

**MALAVIYA NATIONAL INSTITUTE OF TECHNOLOGY JAIPUR  
JAIPUR – 302017 (RAJ.)**

No. F5 ( 541 ) ST/ Hostel/MNIT/2009/  
0141-2713312

Phone :

Fax No. : 0141-2529029

To,

M/s .....

.....

.....

**NOTICE INVITING QUOTATIONS**

1. Quotations are invited for the supply of **Furniture** required for **Girls Hostel Canteen** of this institute as per list attached/given overleaf by **21.05.2009 till 2.00 PM** . The quotations will be opened in the Central Stores at 3.00 PM on 21.05.2009. The covers containing the quotations must be marked "**QUOTATION FOR FURNITURE ITEMS DUE ON 21.05.2009 till 2.00 PM** .
2. **THE RATES QUTOED SHOULD BE F.O.R. JAIPUR** inclusive of all charges e.g. packing, forwarding local taxes, railway freight, transit insurance, for outside firms and free delivery at Institute stores in the case of local firms. The rates may also be quoted separately "ex-godown/F.O.R. despatching station. In case of Ex-Godown rates, please mention your packing and forwarding charges. Where there is no mention regarding delivery period in the quotations or where the items are offered ex-stock, the firms will be required to supply goods within one months time.
3. Quotations should preferably be given only for those articles which are available ex-stock. Other items should be quoted separately giving the delivery period. Rates of imported goods be quoted excluding custom duty as this institution is exempted from payment of custom duty. The rates of indigenious equipments may be quoted without Excise Duty as this institute is exempted from payment of Excise Duty.
4. As far as possible, quotations should be given for goods of India manufacture and foreign goods which are readily available. Foreign goods quoted and proposed to be supplied should be covered by normal import quota of the dealer. This institute is exempted from payment of custom duty.
5. Detailed specifications and "make" of each item should be clearly given supported by the illustrated pamphlets wherever possible. Quotations without specifying the make and other particulars may be rejected. The payment will be made after the goods have been received, opened, checked and found to be in order up to our entire satisfaction. The accessories included in the equipment should also be clearly mentioned.
6. Losses or damage in transit will be in to the account of the supplier in case of rates **F.O.R. JAIPUR**. The supplier may, if he so desires, get the goods insured and include such charges in the tendered rate.
7. The payment for the ordered items would be made after the articles have been received and found in order. Normally payment shall be made through a crossed cheque within 30 days of the receipt of goods.

8. Your rates should be valid at least for six months from the last date of receipt of quotations.
9. All legal proceedings, if necessity arises to institute may be any of the parties (Institute or Contractor/Supplier) shall have to be lodged in the courts situated at Jaipur and not elsewhere.
10. The undersigned is not bound to accept the lowest tender and may reject any tender or any part of the tender without assigning any reason there of.
11. The rates must be quoted item-wise by giving Serial No. of our enquiry letter.
12. The quotations should preferably be sent duly typed.
13. (a) The Penalty Clause is as under :-

Should the tenderer fail to deliver the goods within the period specified in the tender form the purchasing officer may, at his discretion, allow an extension in time subject to recovery from the tenderer as agreed liquidated damages, and not by way of penalty, a sum equal to the percentage of the value of stores which the tenderer has failed to supply for period of delay as stated below :-

(i)	Delay up to one week	1%
(ii)	Delay exceeding one week but not exceeding two weeks	2%
(iii)	Delay exceeding two weeks but not exceeding one month	5%
(iv)	Delay exceeding one month	5% for each month and part there of subject to maximum 10%
- (b) In case of failure to supply the goods within the prescribed time and in accordance with the specifications give in the Quotations, the institute shall be free to cancel the order and make purchases from the next higher tenderer or from the open market as the case may be. In that case the loss sustained by the institute shall be recovered from the defaulting supplier. The institute will be at liberty to recover the loss from the permanent earnest money/or any other pending claims of the supplier without prejudice to its general right to affect recovery from the supplier.
14. EARNEST MONEY : A Demand Draft for Rs. @ 2% of the quoted cost only in the name of the Registrar, M.N.I.T. may please be sent along with your tender as Earnest Money **without which no tender shall be considered. Cheques are not accepted as earnest money amount.** No interest is paid by us on the amount of earnest money.
15. Successful bidder will have to furnish Performance security @10 % of the Furniture Cost, Valid for Six months in the form of Banks Guarantee from Nationalize Bank.
16. Drawing & Specifications enclosed.

(Stores Officer)

**Qty & Specifications :**

<b>S. NO.</b>	<b>ITEM</b>	<b>QTY.</b>
<b>1.</b>	<b><u>Sofa</u> Two Seater Three Seaters</b>	<b>04 Nos. 02 Nos.</b>
<b>2.</b>	<b>Black Leather Cloth Chair</b>	<b>01 Nos.</b>
<b>3.</b>	<b>Canteen Table 4 Seater Set With Chair</b>	<b>08 Nos.</b>
<b>4.</b>	<b>Centre Table</b>	<b>02 Nos.</b>
<b>5.</b>	<b>Corner Table</b>	<b>03 Nos.</b>
<b>6.</b>	<b>Reception Table/Single Arc Type</b>	<b>01 Nos.</b>
<b>7.</b>	<b>LCD TV (SONY)</b>	<b>01 Nos.</b>

# Drawing & Specifications

## 1. Sofa (Two Seater/Three Seaters)

The Sofa should be a lounge seating system standing on beam with side frame assemblies. The LH/RH side frame is fitted to the two ends of the ST/BK mounting frame to form the leg assembly. It should be made of MS. E.R.W. tube dia 4.44 cm. (1.75") x 14 BG. thk and chrome plated. The ST/BK mounting frame assy. holds the two side frames together. The mounting frames, 2nos are used to connect the side frames. The mounting frame should be made of MS. E.R.W. tube dia.5.08cm. (2") x 10BG thk. black painted. The ST/BK should be mounted on 14 BG thk 2cm x 4cm Recta tube which are welded on the beam of ST/BK mounting frame. The ST/BK assembly consists of 12mm thk plywood insert with Polyurethane foam having density = 45 +/- 2 Kg/cm<sup>3</sup> and hardness of the P.U. foam = 18 to 22 Kg on Hampden m/c for 25% compression of the foam. The complete moulded ST/BK assembly is covered with a replaceable fabric upholstery cover. The side frames should be fitted with front and rear bottom shoes made of injection moulded polypropylene.

All external surfaces should be chrome-plated and should withstand min of 100hrs in salt spray test. The fabric should be a stain repellent fabric and velvet in nature so that it be vacuum cleaned in order to remove dirt & grit from the fabric surface. The velvet fabric should be of green colour.

**QTY. (Sofa Set Two Seater)                      04 Nos.**

**QTY. (Sofa Set Three Seater)                    02 Nos.**

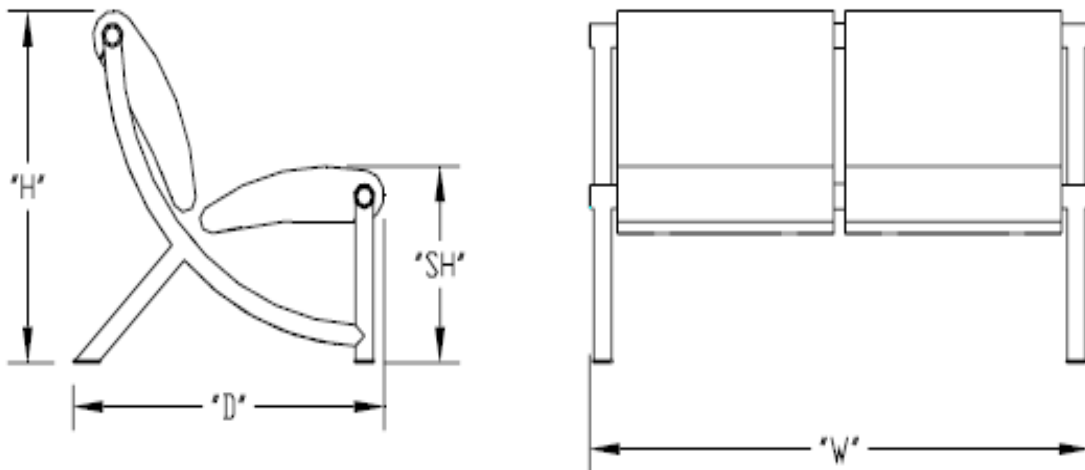

WIDTH (W): 1257.0 CM ±1.0 CM  
DEPTH(D): 783.0 CM  
HEIGHT(H): 750.0 CM  
SEAT HEIGHT (SH): 415.0 CM  
UNSPECIFIED TOL.= ±1.0 CM

## 2. Black Leather Cloth Chair

The seat and back are made from chemically treated and seasoned wood, upholstered with plywood, black leather-cloth, and U-foam.

BACK SIZE: 46.0cm (W) x 27.0cm (H).

SEAT SIZE: 46.0cm (W) x 40.0cm (D).

The armrest tube is made of M.S. E.R.W. tube dia. 2.54cm. (1") x 16BG thick and powder coated. The armrest is gas-assisted injection moulded from black Polypropylene. The understructure assembly is a cantilever type frame made of dia. 2.54cm. (1") x 14BG. thick M.S. E.R.W. tube and powder coated.

**QTY. (Black Leather Cloth Chair)            01 Nos.**

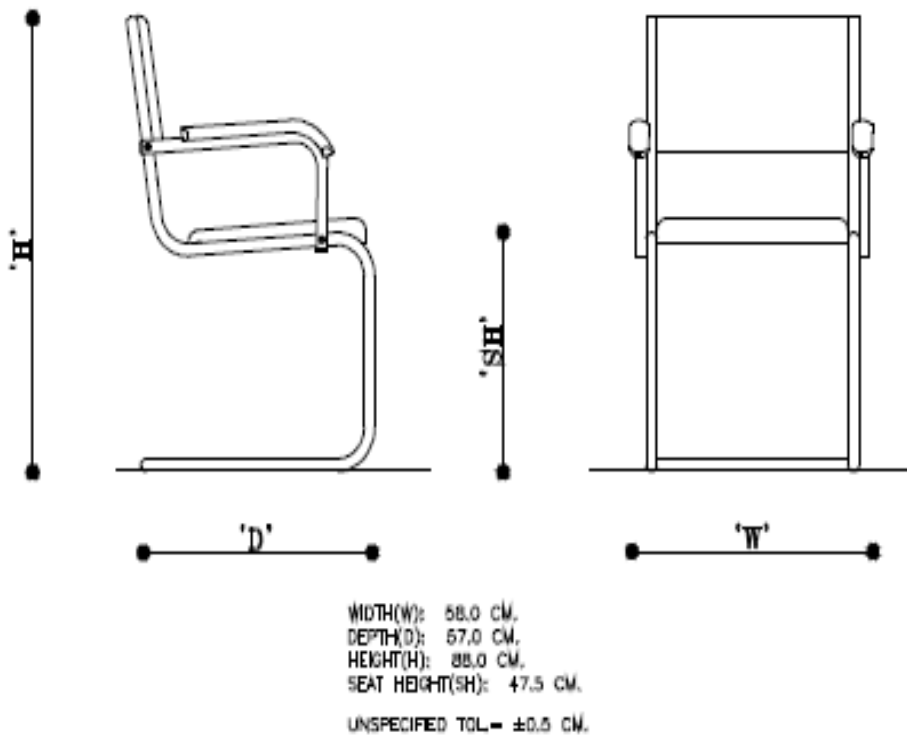

### 3. Canteen Table

Canteen Table should have Top & Tubular Frame. The top should be of stainless steel brushed finish with PLB insert for durability. Easy to clean & maintain hygiene.

The Tubular Frames should be made of 50.8 X 50.8 mm X 1.2 mm thick, as per IS : 7138 – 1973 and powder coated ERW tubes at base which should be welded & fixed to Top with screws. The Table Top is SS 1.0 mm Thk (Brush Finish) wrapped around 18 mm Thk PLB with 5 mm Thk PP Strips along the edges to make it appear over all as 25 mm Thk Top.

Tubular Stiffeners that should be provided between the 2 vertical frames. The tubes to be closed with plastic caps.

Seats should be of Plastic Shell types in red colour.

(Schematic Diagram of a Typical Canteen Table)

**QTY. (Canteen Table 4 Seater Set with Chair)**

**08 Nos.**

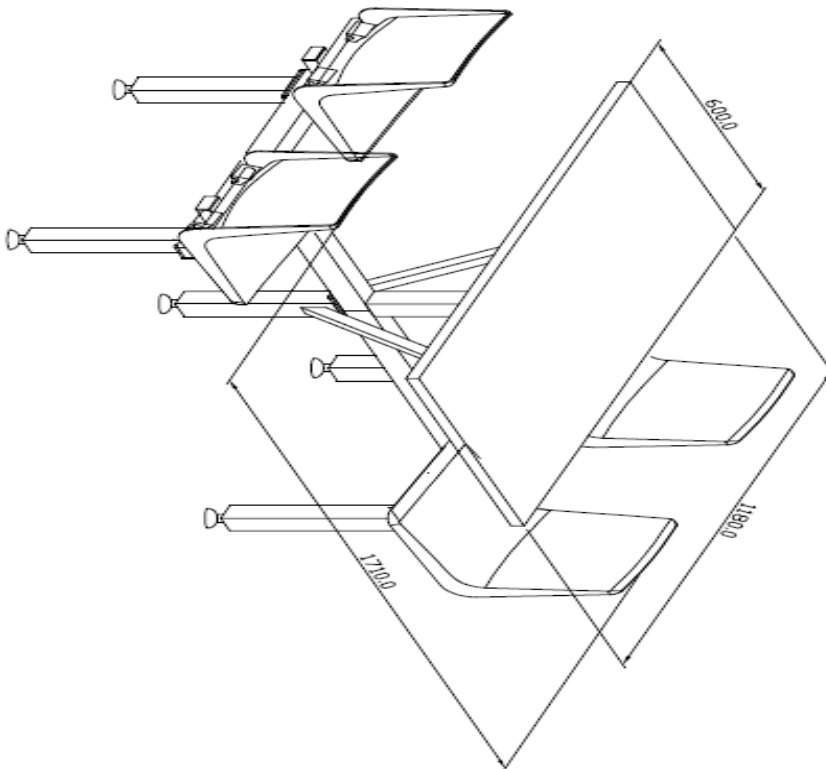

Level adjusters should be provided to take care of unevenness in floor.

Steel Top Size of 4 ft X 2 ft 6 inch with 4 red plastic shell chairs.

#### **4.Centre Table**

Top glass should be 10 mm thk welded to base by UV curing with attractive Stainless Steel discs. and understructure should be Chrome Plated.The overall size of centre table should be as under

Width : 1100 mm

Depth : 600 mm

Ht : 420 mm

Schematic diagram of centre table should be followed as under:

**QTY. (Centre Table)                      02 Nos.**



## 5. CORNER TABLE

CORNER TABLE should be size 450mm(W),530 mm(D) & 400 mm(W). It should have Tempered Glass Top with 8 mm thickness which has a higher load capacity than ordinary glass, with UV disc attached to the base with transparent glue, base material should be of fiberglass reinforced plastic with load bearing capacity of 20kg, the base material which is made up of fiberglass reinforced plastic so as to remain free from rust. Sleek and elegant design which perfectly fits with any decor.

**QTY. (CORNER TABLE)**

**03 Nos.**



## 6. Reception Table/Single Arc Type

The Rubberwood Top in clean matt PU Finish of reception table should be 18mm thick and meet following sizes:

Inside Radius-700mm , Outside Radius 1350mm & Depth 200mm.

The rubberized cork should be of 18mm thick and the frosted glass should be of 10mm thick with diamond cut finishing on the edges and should meet the following sizes.

Inside Radius-1202mm,Outside Radius-1402mm and depth 200mm.

The understructure of table should have modesty panel & legs. The modesty panel should be of Ms-perforated sheet and should be meet the following sizes.

Below work surface – 0.8 mm(T) X 66.5(H) X 130.6mm(L)

Above work surface -0.8mm(T)X260(H)X130.6mm(L).

Legs should be of MS Tube of 1.6 mm thick with 50.8 mm diameter and height to be maintained 604 mm.

**QTY. (RECEPTION TABLE/SINGLE ARC TYPE)**

**01 Nos.**

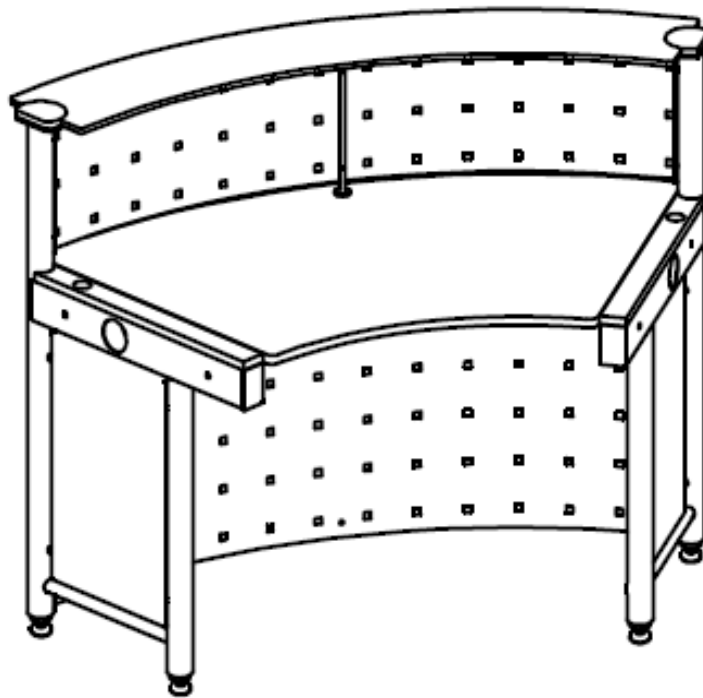

**7. LCD TV (SONY BRAVIA)**

**QTY. 01 Nos.**

Model No. – KLV-32S400A  
LCD Screen – 32(81 cms) (16:9)  
TV System – M, B/G, D/K, 1  
Colour System – NTSC 3.58, PAL, SECAM,  
NTSC 4.43(AV in), PAL 60(AV in)  
Video Signal – 480i, 576i, 480p, 576p, 1080i, 720p 1080p

**Stores Officer**